

- An object of mass m is hanging by a string from the ceiling of an elevator. The elevator is accelerating downward. What is the tension in the string?
 - less than mg
 - exactly mg
 - greater than mg
- The diagram on the right features a massless, frictionless rope and pulley. If m_1 is much greater than m_2 , what is the relationship between T_1 and T_2 ?
 - $T_1 = T_2$
 - $T_1 > T_2$
 - $T_1 < T_2$
 - Impossible to tell
- Two sumo wrestlers are floating motionless in outer space. Suddenly, Sumo A pushes Sumo B. According to Newton's Laws, which of the following must be equal for the two sumos during this push?
 - acceleration
 - mass x acceleration
 - displacement
 - speed
- What property(ies) change(s) significantly when an object is transported from Earth into space?
 - The object's mass but not its weight
 - The object's weight, but not its mass
 - The object's mass and its weight
 - Neither the object's mass nor its weight
- A hockey player is accelerating across an ice rink. Which of the following best describes the force that is pushing her forward?
 - The forward swing of her arms
 - The force of her leg extending
 - The ice pushing against the blade of her skate
 - Her foot pushing against the sole of her skate
 - Her skate pushing against the ice.
- A larger object and a smaller object, both falling from the sky, are each experiencing the same force of drag. Which of the following statements cannot be true about these objects?
 - The larger object is heavier than the small one.
 - The smaller object is falling faster than the large one.
 - The larger object is more aerodynamic than the smaller object (lower C_d)
 - They are falling at terminal velocity.
 - None. These statements can all be true.
- Fred is pushing some boxes horizontally across the surface of a table by applying a constant force of 10N to the rightmost box (as shown). If the surface of the table is frictionless, how does Fred's applied force compare to the contact force between boxes A and B?
 - Fred Force = Contact Force
 - Fred Force > Contact Force
 - Fred Force < Contact Force
 - Impossible to tell
- A stone of mass m is thrown directly upward into air. It goes up; it comes down. If the magnitude of its drag force at any given moment is represented by F_d , what net force is the stone experiencing when it is on its way down? Assume that the upward direction is positive.
 - $-F_d - mg$
 - $-F_d + mg$
 - $F_d + mg$
 - $F_d - mg$
 - $-mg$
- A stone of mass m is thrown directly upward into air. It goes up; it comes down. The magnitude of its drag force at any given moment is represented by F_d . Where in its flight is its acceleration equal to $-9.8m/s^2$?
 - On the way up
 - On the way down
 - At the top
 - Nowhere
 - Everywhere.

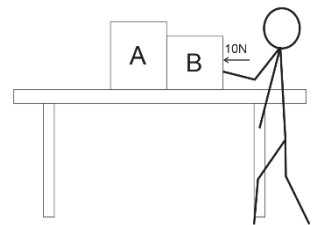

Short Answer:

1. A **50kg** student is standing up in the aisle of a bus as the bus travels rightward toward a stoplight. The bus is currently slowing down. The bus and the student are accelerating at a rate of **-3m/s^2** . The bus' current velocity is 10m/s . The student does not slip or fall, and he remains in contact only with the floor of the bus. On the diagram, draw **all** of the **individual** forces that are **acting on the student**. Use arrows to show the direction of each force. Label each arrow with an appropriate **name** of the force, the **correct magnitude of the force**, and the **correct units**.

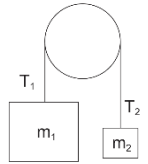
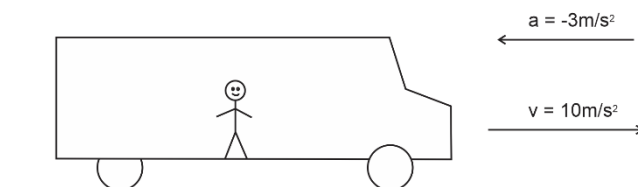

2. A child inflates a typical rubber balloon and drops it from a roof. The balloon reaches terminal velocity as it falls and eventually hits the pavement below. When the balloon hits the pavement, it compresses, bounces back upward, and reaches some new maximum height before falling back to the pavement. Show the changes in the net force acting on the balloon during its journey. **Assume that up = positive**. The graph times are not organized to scale. Force magnitudes do not have to be exactly to scale. The pictures below the graph are meant to help you understand what is happening to the balloon at each moment.

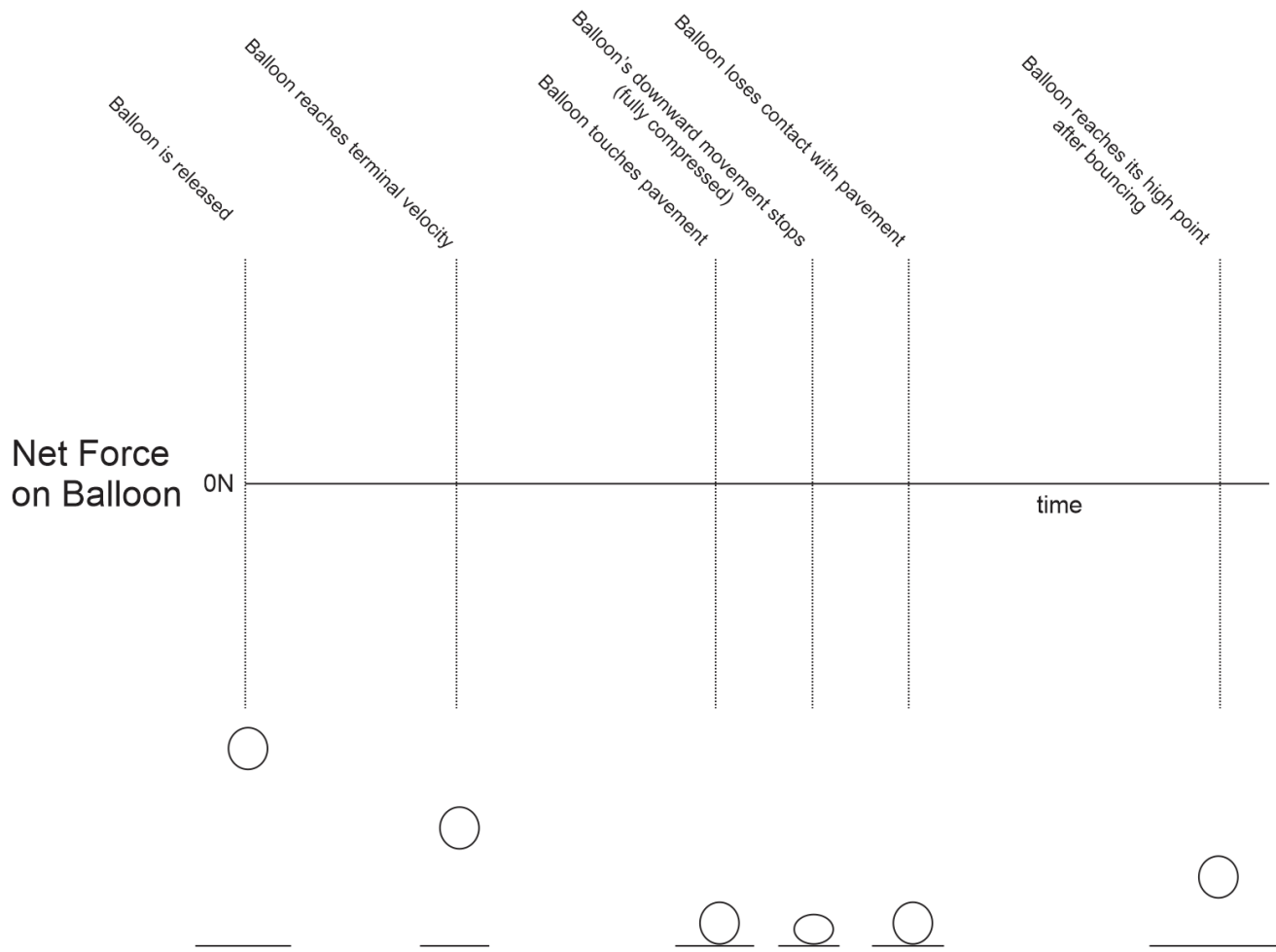

3. A **10kg** brick is dropped from a helicopter. The brick falls until it reaches terminal velocity, falls some more, and then it hits the ground. The table below provides incomplete descriptions of three moments during the brick's descent (labeled A-C). They are intentionally scrambled so that they are not in order! Use the second column to correctly order the moments in time. Also enter the correct drag force and net force for each of the moments.

Moments in the descent	Order (1=occurs first, 3 = occurs last)	Brick Weight [Not Graded]	Force of Drag on brick	Net Force acting on brick	Brick Acceleration
A			98N		
B			0N		
C			49N		

4. Describe the action and reaction forces that explain how a walking person accelerates forward.

Action:

Reaction:

Problems:

1. A student weighs 600N on Earth.

a. What is his mass?

b. On a different planet, the acceleration of gravity is 0.7g. What weight would the student have on that planet?

2. Pam pushes a block of wood so that it accelerates at a rate of 3.2m/s^2 .

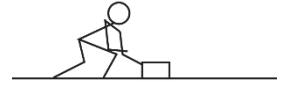

a. If the block of wood has a mass of 3kg , what net force must be acting on the wood block?

b. If Pam's 3kg block of wood has a coefficient of kinetic friction (μ_k) of 0.4 , what friction force is acting on the block while Pam is pushing it?

c. Given the same block mass and friction as above, what force must Pam be applying in order to make the block accelerate at this rate (3.2m/s^2)?

d. How fast would the block of wood accelerate if Pam applied this same force (from part c), but there were no friction ($\mu_k=0$)?

3. A 60kg student is standing on a bathroom scale in an elevator, and the scale currently reads 500N. Describe the acceleration of the elevator? (provide magnitude and direction)
4. Matilda and Vern are hoisting tools up to a roof so that they can begin a roofing project. One of their saws has a weight of 90N, and Matilda wants to be able to lift it from the ground to the roof (a height of 7m) in exactly 7 seconds.
- How fast must the saw accelerate in order to ascend a height of 7m in 7seconds, starting from rest?
 - How strong does the rope need to be in order to lift the 90N saw at this rate? Give its minimum breaking strength, in Newtons.

5. The diagram on the right shows three masses connected by frictionless, massless strings passing over frictionless pulleys. The coefficient of friction between the sliding mass and the surface is $\mu_k = 0.3$, and the masses and strings are in motion.

a. Find the acceleration of the entire system of masses and ropes.

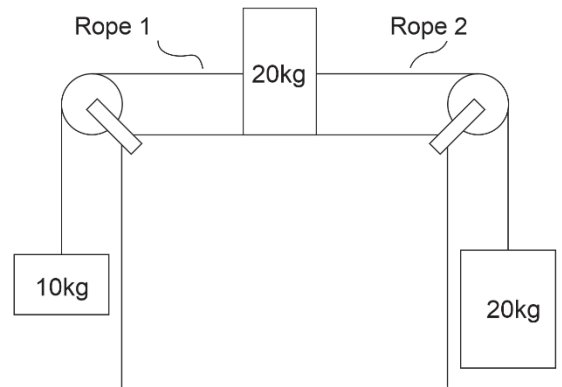

b. Find the tension in Rope 1

c. Find tension in Rope 2.