

Part 1: Make your target

1. Roll some copier paper into an 8.5" long tube (i.e. roll parallel to the paper's long axis) that you think would be a good diameter for a Nerf dart target. Secure the roll with clear tape.
2. Close off one end of the tube and secure the closed end with tape.
3. Get a wooden stick with pre-cut grooves spaced 10" apart.
4. Hot glue the stick to your tube. The grooves should face the tube, and the tube should be centered between the grooves. The long axes of the tube and stick should be parallel.
5. Cut about 3' of fishing line.
6. Tape the fishing line to the outside bottom (opposite the stick) of the open end of your tube. The free end of the line should be directed out of the tube's mouth.
7. Loosely stuff a tissue in your tube.

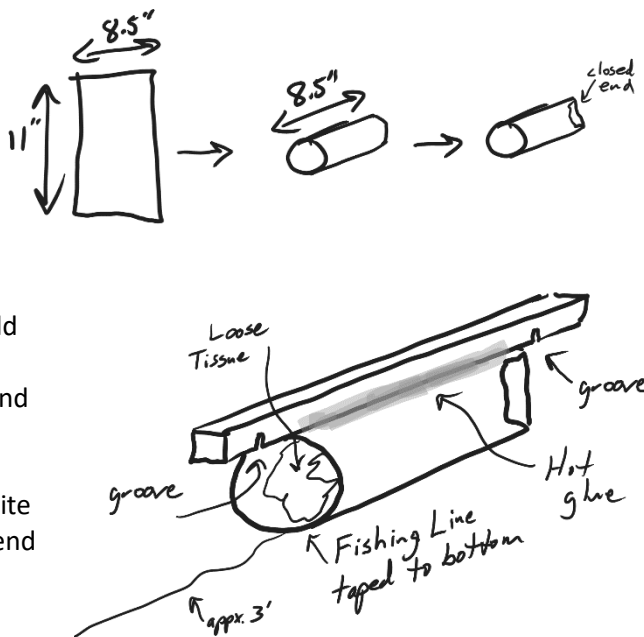

Part 2: Get ready to launch.

1. Get a Nerf launcher and one Nerf dart. Take good care of your dart! We were not given extras, and I would like to return them in good condition to our gracious benefactor.
2. Stand near the pendulum and watch the group(s) ahead of you collect their data. When it's your turn...
3. Hang your target on the pendulum strings, with each string in one of your target grooves.
4. Run the fishing line down to the table top, and then over and across the Velcro, as shown. Sandwich the fishing line gently (loose but secure) between the pair of Velcro pieces. Extend the rest of the fishing line away from the target. When the target is hit, the line should slide smoothly through the Velcro. When it's time for launch, you may want to have a helper support the free end of the line, to maximize its smooth flow.
5. Pull the free end of the fishing line until most of the slack is gone.
6. Adjust the target so that the stick is parallel to the blue tape on the table (or until it looks right to you).

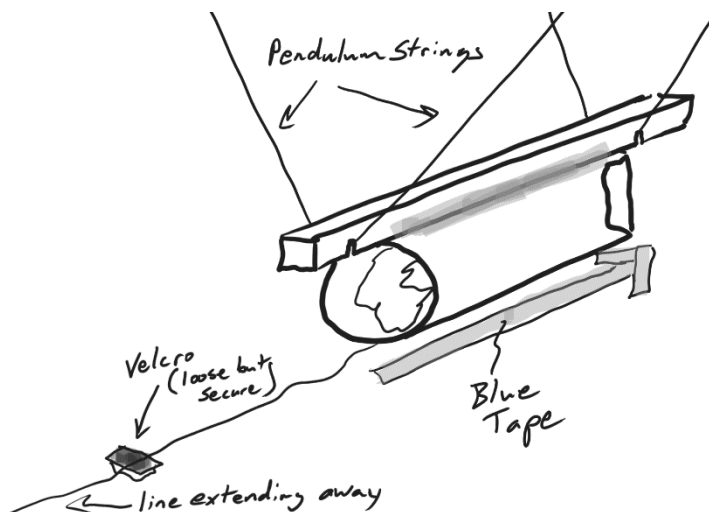

Part 3: Launch

1. Insert your Nerf dart and cock your launcher.
2. Hold the launcher parallel to the target, with the muzzle pointing at the direct center of the target mouth.
3. Fire.
4. As soon as the initial swing is complete, use your finger to prevent any additional movement of the fishing line through the Velcro.

- If the swing looked good to you, move on to step 6. If the swing was too violent and high to measure precisely, remove your target and add some mass to it. 15 grams should be plenty for the Nerf launchers we are using. After you have adjusted the mass, repeat the launch. On the other hand, if your target moves too little, you can also remove some mass from your target.
- If your dart is still in the target, proceed to part 4. If your dart is not in the target, make adjustments to keep the dart in, and repeat parts 2 and 3.

Part 4: Measure the swing height

- Leave the dart in the target and return the target to its original position.
- Use a ruler to measure the height of any part of the target. Record that height in the **data table**.
- Holding the fishing line in place at the Velcro, pull the target through its swing until the Velcro just becomes taut. Re-measure the target height at the same part of the target where you measured before. Record this height in the **data table**.
- Remove your target/dart so that the next group can use the pendulum.

Part 5: Measure masses

- Remove your dart. Measure and record both the dart mass and the target mass. You can decide what to do about the mass of the fishing line (it should be negligible).

Part 6: Perform calculations – **you may want to do all of this on the spreadsheet (template provided in Google Classroom). That’s where you will ultimately be turning this in.**

- Convert your heights to meters.
- Convert your masses to kg.
- Find the dart velocity (in m/s) before it’s collision with the target.
- Convert the dart velocity to mph and to feet per second (the traditional velocity unit for Nerf darts).

Part 7: Repeat

- Calculate a velocity for each of 3 different Nerf launchers. 2 launchers will be assigned. One will be your choice.

Data Table:

	1 <sup>st</sup> Launch	2 <sup>nd</sup> Launch	Choice Launch
<b>Launcher Number</b>			
<b>Target starting height (cm)</b>			
<b>Target max height (cm)</b>			
Swing height (cm) – max height minus starting height			
<b>Target mass (g)</b>			
<b>Dart mass (g)</b>			
Dart velocity before impact (m/s)			
Dart velocity before impact (mph)			
Dart velocity before impact (fps)			